



Reliance Industries, LLC

**Installation, Operation, Inspection and Maintenance
Instructions for the Skyline™ Horizontal Lifeline System**

6350

**Portable Structural Steel Lifeline System using
3/8 – 7x19 Steel Wire Rope with Ratchet Tensioner and the
Skyline™ Shock Absorber**

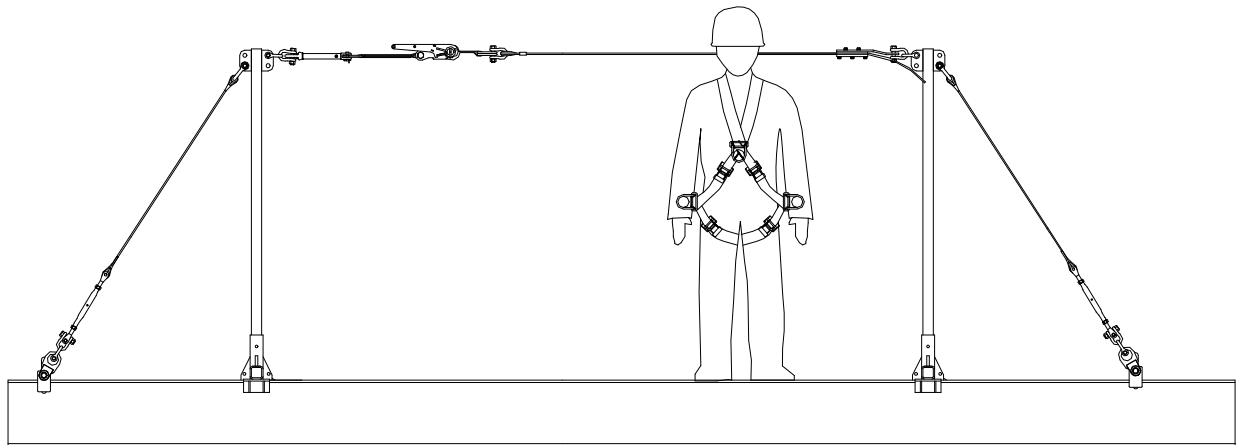

Reliance Industries, LLC

PO Box 140008

Denver, CO 80214

Ph. (800) 488-5751

Ph. (303) 424-8650

Fax (303) 424-8670

US Patent #6,338,399 and other Patents Pending



User Instructions

6350 Skyline™ Structural Steel HLL System

Reliance Industries, LLC

Important Instructions!

These instructions must be kept on file and available for the users reference at **all** times. The users must read and fully understand these instructions or have the instructions explained in detail before using this equipment. **Failure to observe these instructions could result in serious injury or death.**

Prior to use, all workers must be trained in the proper use of all systems and equipment.

A Training and Instruction review should be repeated at regular intervals.

A rescue plan must be prepared; the workers must be trained in its use, and rescue equipment must be on hand prior to any use of this horizontal lifeline system.

Any questions regarding these instructions should be directed to:

Reliance Industries, LLC
PO Box 140008
Denver, CO 80214
Ph. (800) 488-5751
Ph. (303) 424-8650
Fax (303) 424-8670



Table of Contents

IMPORTANT INSTRUCTIONS! 2

SYSTEM DESCRIPTION..... 5

ANCHORAGE POINTS..... 6

HORIZONTAL LIFELINE SYSTEM COMPONENTS 6

PERSONAL FALL ARREST EQUIPMENT USED WITH HORIZONTAL LIFELINES 7

INSTALLATION LAYOUT CONSIDERATIONS 8

INSTALLATION 9

TOOLS REQUIRED FOR A TYPICAL STRUCTURAL STEEL SYSTEM INSTALLATION..... 13

HLL INSTALLATION PROCEDURES 14

LIFELINE INSTALLATION UTILIZING STRONGBACK BEAMS 19

INSTALLING THE 3093 ANCHOR CLAMP 19

TRAINING 20

PLANNING FOR RESCUE..... 20

INSPECTION..... 21

SERVICING 22

WARNINGS AND LIMITATIONS 22

INSPECTION LOG FOR HLL SYSTEMS..... 23

SKYLINE™ HORIZONTAL LIFELINE DIAGRAM..... 24



User Instructions

6350 Skyline™ Structural Steel HLL System

Reliance Industries, LLC

Important OSHA Regulations Covering the Use of Horizontal Lifeline Systems

OSHA 1910.66 Subpart M – 1926.502 (d)(8):

Horizontal Lifelines shall be designed, installed, and used under the supervision of a qualified person as part of a complete fall arrest system, which maintains a safety factor of at least two.

OSHA 1910.66 (b):

“Qualified Person” means one with a recognized degree or professional certificate and extensive knowledge and experience in the subject field who is capable of design, analysis, evaluation, and specifications in the subject work, project, or product.

OSHA 1910.66 (b):

“Competent Person” means a person who is capable of identifying hazardous or dangerous conditions in the personal fall arrest system or any component thereof, as well as in their application and use with related equipment

OSHA 1910.66:

Personal fall arrest systems shall be rigged such that an employee can neither free-fall more than 6-ft. nor contact any lower surface.

OSHA 1910.66 (n):

The sag in the lifeline should be minimized to prevent the connecting piece of equipment (self-retracting lanyard or other appropriate personal fall arrest device) from sliding down the lifeline to a position, which creates a swing hazard during a fall arrest.

OSHA Standards, Interpretations and Compliance Letters, 02/09/1995-Criteria for personal fall arrest systems:

The free-fall distance is limited to 6 feet. The deceleration distance must not exceed 42 inches; lifeline elongation is not included in deceleration distance; and the total fall distance is unregulated except that the employee cannot make contact with a lower level...The safety factor of two should be applied based on the anticipated maximum arrest force, not the fall energy.



User Instructions

6350 Skyline™ Structural Steel HLL System

Reliance Industries, LLC

System Description

The Skyline™ Horizontal Lifeline System P/N 6350 is designed for use as a portable horizontal lifeline system where structural steel is present, such as during building construction. Its' lightweight materials allow for easy installation and removal, yet the rugged construction allows for a long service life in demanding construction environments. The lifeline is constructed of 3/8-in. – 7x19 wire rope and is available in both galvanized (IPS) and stainless steel versions and uses a unique ratchet load binder for rapid tensioning of the Skyline™ lifeline to the proper load. It is designed to enable the user to attach to an engineered fall arrest system in work areas where no overhead anchor points exist. The system, in general, is designed for use by up to 4 persons at the same time, and can span distances up to 200-ft. However, span length and number of persons on the system determine input energy (and therefore, final line tension) and not all combinations of span lengths and number of workers are possible. The user must consult the manufacturer for exact system parameters for each installation, or in the event that the system is moved. System parameters are provided in the form of computer generated load and Minimum Required Clearance (MRC) data that is traceable to our data and test results for each system installation.

The computer generated designs are prepared from verifiable test data and include a 2-ft. safety factor for Minimum Required Clearance for a vertical fall, and a 2 to 1 Safety Factor over the minimum cable breaking strength for maximum allowable line tension.

This system design is predicated on the use of a full-body harness for the worker, double-action, single-locking snap hooks to attach to the lifeline, and a shock absorbing vertical lifeline or self-retracting lanyard (SRL) with a 900 lb. Maximum Arrest Force (MAF). Non-shock absorbing lanyards and retractables that do not have “slip-clutch” type internal shock absorbers with a 900 lb. maximum MAF are **NOT** allowed for use as vertical lifelines on this system. Any attachment to the horizontal lifeline must transfer fall arrest forces to the body through the dorsal d-ring of the full body harness only. Harness side and chest d-rings are not allowable lanyard connection points.

All Skyline™ HLL systems are supplied with an integral shock absorber in the line and no system may be used without one. The four main functions of the shock absorber are:

1. It adds energy capacity to the system to increase the safety of short horizontal lifelines.
2. It adds hysteresis (friction) to the system to absorb rebound energy.
3. It decreases low sag angle amplification by controllably elongating the horizontal lifeline.
4. It allows the cable to be tuned (or pre-loaded to a higher initial line tension) to force the cable to absorb energy at a higher rate.

The shock absorber has a built in spring-loaded tensioner that indicates when the proper pre-tension has been achieved. Normally the pre-tension is set at 1000-lb. but may be changed for specifically designed applications.



User Instructions

6350 Skyline™ Structural Steel HLL System

Reliance Industries, LLC

When a system is installed, the pre-tension must be set according to the installation instructions. Not all systems are perfectly rigid; therefore, pre-tension may change over time. Prior to each use, the worker must check the pre-tension of the system and adjust it accordingly. When the pre-tension of a system is closely controlled, the fall distance and final line tension are easily predictable. Knowing that the pre-tension of a horizontal lifeline is set correctly is of utmost importance to the predictability and safety of the system.

Anchorage Points

The strength of horizontal lifeline anchorage points must be at least two times the anticipated line tension. This strength must be certified by a qualified person and must be verifiable by either calculation or testing. Anchorage connectors must be selected carefully. Eyebolts should not be used if they will be loaded at an angle to their axis, unless the loads fall within design parameters for such use. Weld-on lugs should not be less than 1/2-in. in width and should not be made of steel with less than 50,000-PSI yield strength. The proper stress areas and weld areas must be calculated to assure proper safety. If in question, consult Reliance engineering staff for proper design requirements.

Horizontal Lifeline System Components

The Skyline™ Horizontal Lifeline System for Structural Steel consists of the following standard approved and compatible components:

- 1 ea. Model 6310-1 Portable Skyline™ Horizontal Lifeline Kit which includes the following components:
 - 1 ea. Model 6000 Skyline™ Shock Absorber (stainless steel)
 - 1 ea. Model 6050 Steel In-Line Cable Clamp (zinc plated carbon steel)
 - 5 ea. Model 6062 1/2-in. bow shackles (stainless steel)
 - 1 ea. Model 6090 3-in. Ratchet Assembly
 - 1 ea. Model 6092 10-ft. Ratchet Strap, 3-in. wide

(The above components in the 6310-1 kit, along with the appropriate length of cable may be utilized as the basic building block for other Skyline™ Portable Lifeline systems, such as the Looped Rebar HLL for highway applications; the Stanchion Rebar HLL system for concrete applications, and to existing structural steel columns utilizing the 3093 beam clamp and associated 3091 by-pass assemblies; and other applications.)

- 2 ea. Model 6066 5/8-in. bow shackles (stainless steel)
- 2 ea. End Stanchions, 2-in. square steel tube, (60-, 72-, or 84-in. tall depending on HLL system design)
- 2 ea. Model 6077 3/8-in. x 21-ft. Tie-back cable assembly
- 2 ea. Model 6240 HLL Stanchion I-beam Clamp, for flanges 4- to 14-in. wide
- 2 ea. Model 3093 HLL Anchor Clamp



User Instructions

6350 Skyline™ Structural Steel HLL System

Reliance Industries, LLC

(This clamp (Model 3093) can be used for either termination of the 6077 tie-back assembly or for direct connection to the 6310-1 Portable Skyline™ Horizontal Lifeline Kit)

To complete the Skyline™ Horizontal Lifeline System, a Reliance Industries wire rope must also be used. The cable options are as follows:

- 1 ea. Model 6070 3/8-in. – 7x19 IPS galvanized wire rope

or

- 1 ea. Model 6072 3/8-in. – 7x19 stainless steel wire rope

where the length of your cable is dependent on the specific horizontal lifeline system design.

The above list of components represent those items that are most commonly used in horizontal lifeline system designs for structural steel applications. Reliance maintains a varied inventory of HLL Stanchion I-beam Clamps that accommodate structural steel up to 28-in. in width with up to 2-in. thick flanges in both top- and bottom-flange mounting versions. Optional 4 lug End Stanchions are also available for the termination and continuation of crossing horizontal lifelines in work areas that possess adequate structural strength and geometry. Not all systems will use all of these components, and some designs may require additional components not shown (additional tie-back cables, bypass stanchions, or clamps, for example). Please contact Reliance Engineering at (303) 424-8650 for help in designing and selecting the proper equipment for an application.

The actual selection of components and options for the design of a horizontal lifeline system should only be performed by a Qualified Person, or a state registered Professional Engineer who is experienced in the design and use of safety systems.

The Skyline™ Horizontal Lifeline system is designed for use with the approved, above listed components only. Substitutions or replacements with non-approved components will endanger the system integrity and may affect the safety and reliability of the total system.

Personal Fall Arrest Equipment Used with Horizontal Lifelines

It is of utmost importance in the design of horizontal lifelines to be able to predict the vertical fall arrest forces that will be imposed on a lifeline during a fall. Normally, the lifeline will elongate under increasing tension until the horizontal lifeline imposes a 900-lbf. vertical force on the shock absorbing lanyard and then the lanyard will begin to rip out (or extend in the case of a SRL) until all of the fall energy has been absorbed. For multiple persons this force increases as a multiple of 900-lbs. The shock-absorbing lanyard, therefore, is vital in predicting and limiting horizontal lifeline tension. Only shock absorbing lanyards (or SRLs) with 900-lb. Maximum Arrest Force are allowed for use with this system.



User Instructions

6350 Skyline™ Structural Steel HLL System

Reliance Industries, LLC

Care should also be used in selecting and fitting a harness for use with horizontal lifeline systems. Due to the HLL sag height, additional distance required for clearance when using horizontal lifeline systems is often the limiting factor in determining whether a HLL system can be used for a particular application. Harnesses with sewn down or large non-moving back pads can limit as much as 1 ft. of back pad slippage during fall arrest, providing additional clearance for safety. If the system will be used where a worker could encounter a head first free-fall, a non-secured back pad can slide down the webbing to the small of the back, allowing the worker to fall out of the harness through the top by allowing the harness straps to slip over the shoulders. For this reason, we recommend careful consideration of both the type of work, and the manner in which it will be performed prior to the selection of personal fall protection equipment.

Installation Layout Considerations

Most HLL installations consist of either single-span or multi-span systems. Single-span systems consist of two end anchorages with a single HLL lifeline attached between them. Multi-span systems consist of two end anchorages and multiple intermediate (bypass) supports through which the cable passes, but which it is not attached. Normally the bypasses consist of a structure that will allow a lanyard snap to pass through without allowing the cable to become disconnected without damaging the cable. The bypass fittings are also designed to take loads imparted by system deployment. Input energy into an HLL system during fall arrest is usually determined by span length. The longer the span, the farther a person will fall during fall arrest and therefore, the greater the input energy. The more people that fall on a system at one time, the greater the falling weight and this also increases the input energy. In order to limit input energy into a system, one must limit the number of persons on a system and also limit the span length (the peak line tension that a horizontal lifeline experiences during a fall arrest goes up as span length increases and must be monitored to ensure it does not go past the 2 to 1 Safety Factor limit of the lifeline system). On the other hand, the cable, having the greatest energy capacity (or ability to absorb energy) of all the components of a system due to its ability to strain under stress, must be long in order to absorb the greatest amount of energy. Therefore, the safest way to rig and assemble a horizontal lifeline system is to use the longest cable length possible with bypass supports located to reduce sub-span length to as short as possible. Only minimum required clearance limits (MRC) should be used to determine maximum allowable line length.



User Instructions

6350 Skyline™ Structural Steel HLL System

Reliance Industries, LLC

Installation

Installation of horizontal lifeline systems should be done under the supervision of a Qualified Person trained in their function and use. Use only parts that have been qualified as compatible components by Reliance Industries. Install the system only as specified in the system parameter documents prepared by the computer program system. Ensure that the minimum anchorage strength is at least 2 times the anticipated load called out in the system parameter documents. Have the anchorages certified by a qualified person and keep documentation on hand. HLL calculations for minimum required clearance (MRC) are measured vertically below the walking/working surface and assume that the horizontal lifeline is at least 5-ft. above the walking/working surface (unless otherwise specified) in order to limit free-fall to 6-ft. or less as required by OSHA.

HAZARDOUS SITUATIONS: When working on a structure, do not take unnecessary risks such as jumping or reaching too far from the edge of the structure. Be aware of hazards in your work area such as electrical hazards or moving machinery. Do not allow the connecting subsystem to pass under the arms or between the feet. *Never climb above the Skyline™ HLL system or far off to the side since inadequate fall clearance or a swing fall could result.*

Always install lifelines horizontally where all end anchorages and bypass supports are at the same elevation. Never change vertical or directional slope without close supervision of Reliance Engineers. Always install the system per the system parameter documents and NEVER change span length, sub-span length, or number of people allowed on the system. Remember, horizontal lifeline dynamics change with any changes to span length, or number of people allowed on the system. Any changes require a new design, and MUST be approved by a Qualified Person.

User Instructions

6350 Skyline™ Structural Steel HLL System

Reliance Industries, LLC

The system may be installed with the cable running parallel with the axis of the structural steel such as on the top bay of a pipe-rack (see Figure 1 below).

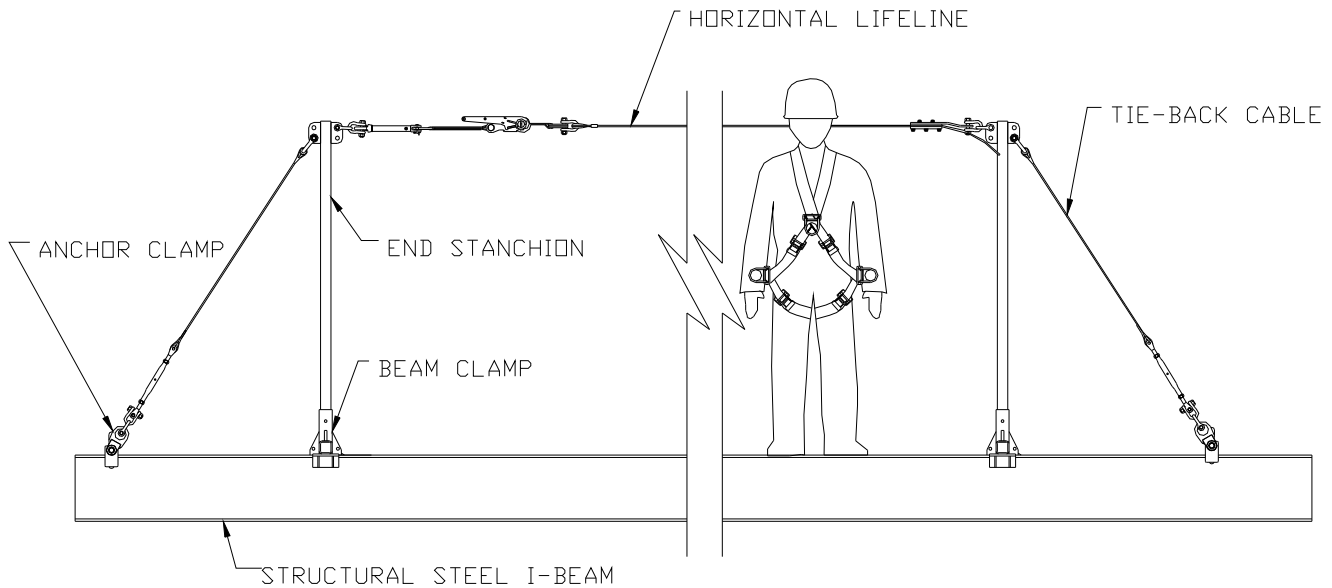

Figure 1 – Lifeline running parallel to the structural steel

The system may also be installed on structural steel beams that run perpendicular to the axis of the HLL such as on the structure shown below (see Figure 2). Additional consideration should be given to the placement of tieback assemblies in this application due to the load amplification and the resulting potential twisting effect of the tie-backs on the structural beams. Also, care must be taken not to overload longer beams when connecting at their midpoints. This configuration could decrease the tieback anchorage strength as a function of unsupported beam length and should be approved by your field engineer or other qualified professional engineer. Maximizing tieback strength can be accomplished in lateral beams by attaching dual tieback anchorages as close to the structural joints (beam ends) as possible.

User Instructions
6350 Skyline™ Structural Steel HLL System

Reliance Industries, LLC

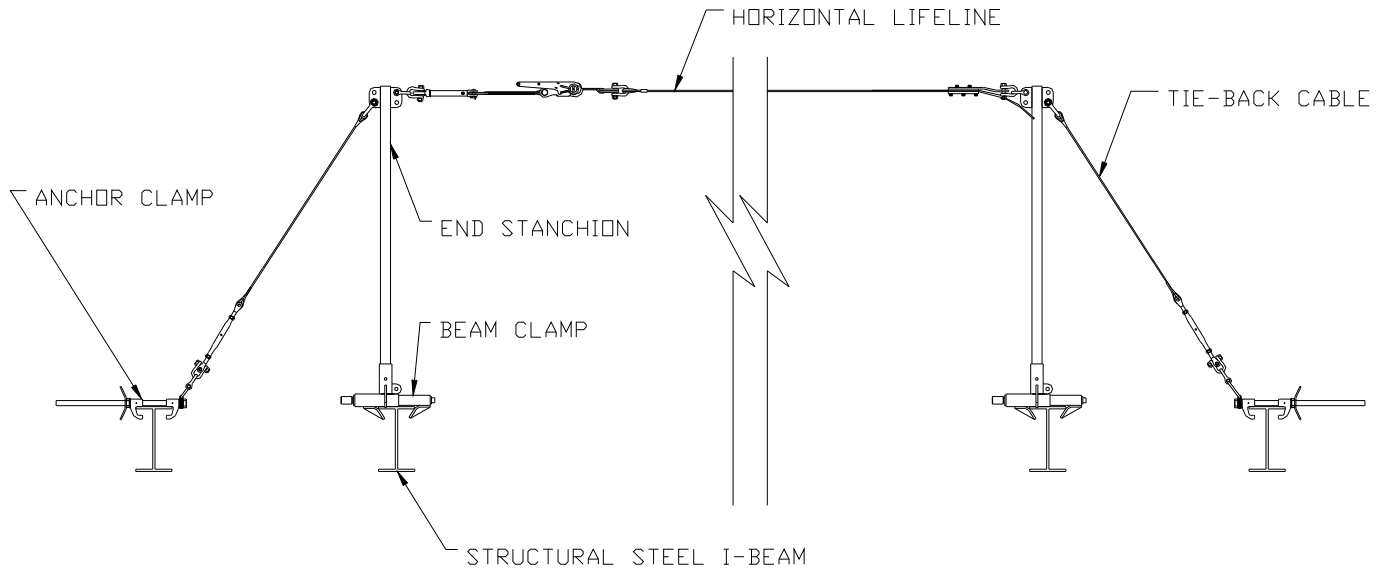

Figure 2 – Lifeline running perpendicular to the structural steel

User Instructions

6350 Skyline™ Structural Steel HLL System

Reliance Industries, LLC

The layout of the most typical components for a standard Structural Steel System layout are:

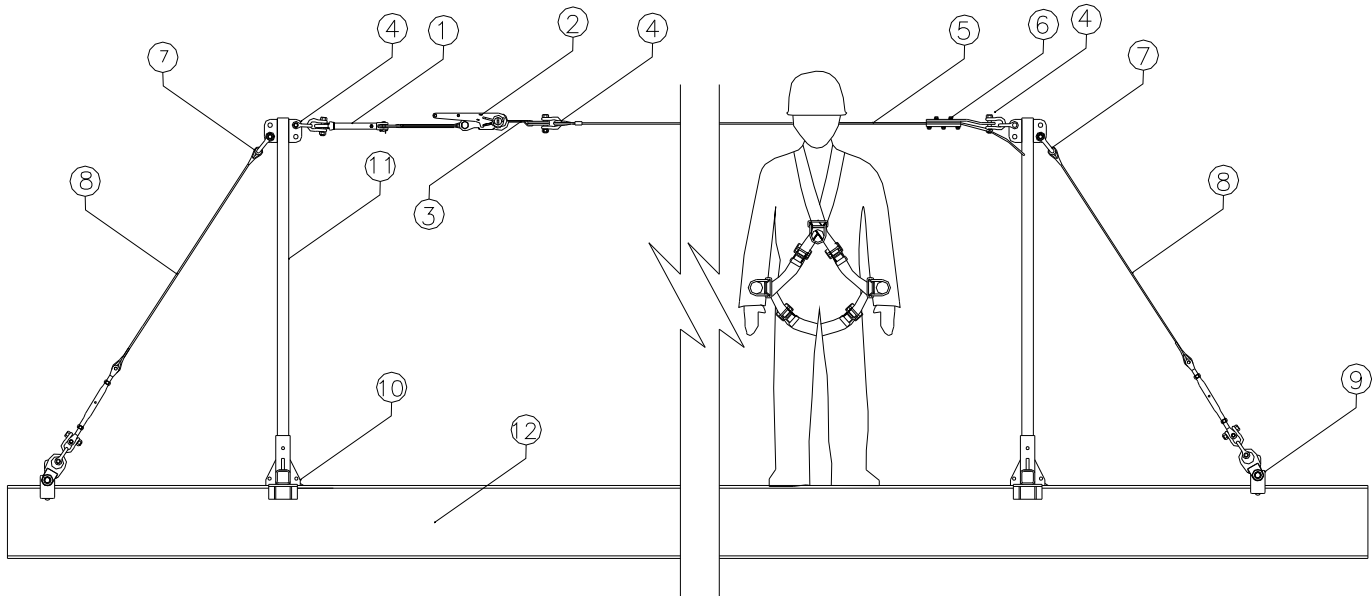

Figure 3 – Components of a typical Structural Steel System

- | | |
|---|--------------------------------------|
| 1. Skyline™ Shock Absorber, P/N 6000 | 7. 5/8-in. Bow Shackle, P/N 6066 |
| 2. 3-in. Ratchet Assembly, P/N 6090 | 8. Tie-back Cable Assembly, P/N 6077 |
| 3. 3-in. x 10-ft. Ratchet Strap, P/N 6092 | 9. HLL Anchor Clamp, P/N 3093 * |
| 4. 1/2-in. Bow Shackle, P/N 6062 | 10. HLL Beam Clamp, P/N 6240 |
| 5. 3/8-in. wire rope, P/N 6070 (gal),
or 6072 (SS) | 11. End Stanchion (5-, 6-, or 7-ft.) |
| 6. In-Line Cable Clamp, P/N 6050 | 12. Structural Steel I-Beam |

* P/N 6093 may be replaced with 6235 Underslung HLL Beam Clamp for situations where the top flange is inaccessible, or P/N 6240 HLL Beam Clamp.



User Instructions

6350 Skyline™ Structural Steel HLL System

Reliance Industries, LLC

Tools Required for a Typical Structural Steel System Installation

The tools required for a typical Structural Steel Lifeline System Installation include, but are not limited to the following:

Box end and combination wrenches

- 1 1/16-in. (for cable clamps)
- 3/4-in. (for combination clamp)
- 5/8-in. (for In-Line Cable Clamp)
- 15/16-in. (for cable clip on tie-back assembly)
- 1-1/8-in. (for 6240 Stanchion Receiver Beam Clamp)

Ratchets and sockets, in a 3/8-in. or 1/2-in. drive size:

- 3/4-in. (for the combination clamp)
- 5/8-in. (for the In-Line Cable Clamp)
- 1 1/16-in. (for the cable clip on tie-back assembly)

Miscellaneous tools:

- Torque ratchet or wrench (preferred)
- Crescent wrenches; large (up to 1-3/4-in.), and small (up to 3/4-in.)
- Screwdrivers (used for rigging screw tightening on tie-back assy. One must be large Phillips to fit hole for final tightening)
- Hammer (to tighten handle of 3093 Anchor Clamp)
- Permanent marking pen to mark cable & affix labels
- Lithium grease for stainless steel thread lubricant on rigging screw
- Tape measure

User Instructions

6350 Skyline™ Structural Steel HLL System

Reliance Industries, LLC

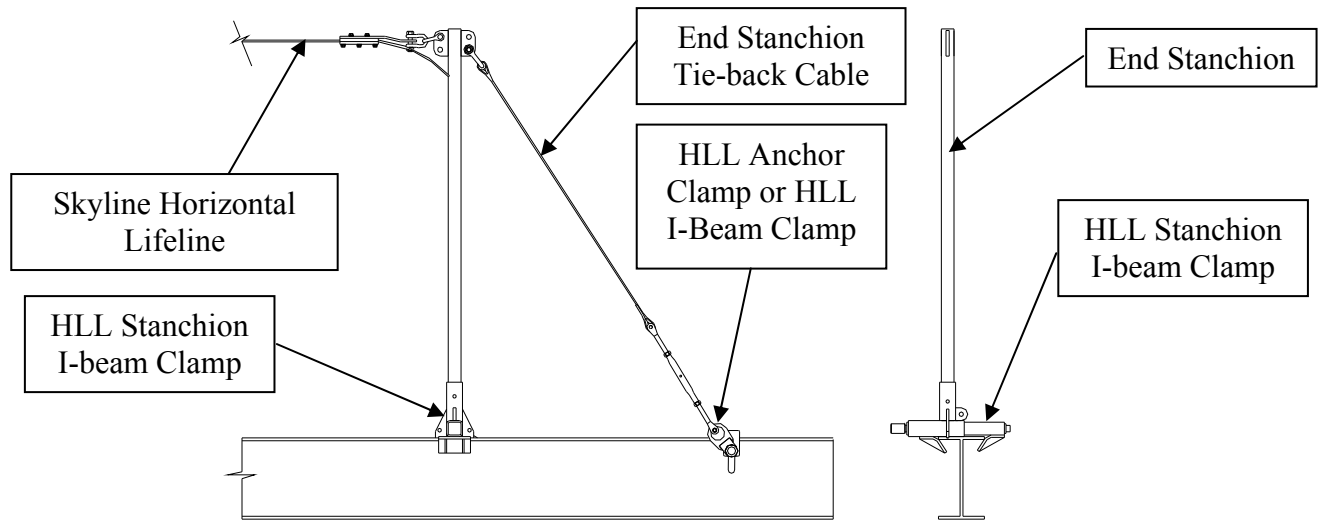

Figure 4

HLL Installation Procedures

NOTE: Approved fall protection must be worn during Skyline™ lifeline installation at all times. Do not use the horizontal lifeline or its anchorages as personal fall protection anchorages until the system has been completely installed, inspected, and approved for use by a Qualified Person. Where possible, Reliance recommends the use of man-lifts or safe access to a guarded structure for rigging end terminations and erection of the Skyline Portable system. When engineering controls are unavailable to rig the lifeline, perform a JSA (job safety analysis) prior to the installation to determine all hazards and establish “safe-task” procedures to minimize the risks present. In addition to the typical fall protection solutions, consider remote anchorage connectors (such as Skyclamp™ and remote connection pole for utilizing anchorages up to 20-ft. overhead), Screw-jack fixed beam clamps for installing a localized anchorage point at the same level as the harness dorsal d-ring, or sliding beam clamps to prevent falls to lower levels or minimize the effect of pendulum-swing falls. Although positioning lanyards have fallen into disfavor because of misuse, consider their use essential as primary-fall protection while pre-tensioning the line on un-guarded platforms or structures. A qualified design person should consider if an erected single-span lifeline (limited to 1 or 2 installers) could be utilized safely as a fall protection system to erect other sub-span bypasses and minimize risk for installers. One option for providing temporary fall protection to the installer during installation is for a SINGLE worker to attach to a bow shackle in the bottom hole of an end stanchion using a 6-ft. shock-absorbing lanyard (maximum length) only after the 6240 HLL Anchor Clamp has been properly tightened to 75- to 90-ft. lb. and the end stanchion has been bolted into place. The only method of attachment permitted in this case is to use a carabiner passed



User Instructions

6350 Skyline™ Structural Steel HLL System

Reliance Industries, LLC

through the eye of the shock-absorbing lanyard snaphook (not the gate opening) and the bow shackle in the bottom hole of the end stanchion. Only one person may be attached to any one-end stanchion at a time. Upon completion of the HLL installation, ONLY the HLL is to be used for fall protection; the SRL must be removed from the stanchion.

1. Identify the location where the first end stanchion (the end attachment point of the horizontal lifeline) is to be located. Depending on the exact layout of the lifeline, it should be far enough down the beam so as to allow for the tieback cable anchor clamp to attach to the I-beam such that it will be positioned properly. At a minimum, the tieback distance should be equal to or greater than the stanchion height. Contact Reliance Engineering for assistance in determining proper placement if questions remain.
2. Widen the jaws of the 6240 I-beam clamp to slide over the I-beam flange. Position the clamp at the right location, and tighten the clamp to the I-beam after squaring the clamp to the beam. Torque the tightening nut of the clamp to 75- to 90 -ft. lb.
3. Slide the end stanchion tube into the receiver tube of the I-beam clamp, making sure that the anchor lugs of the stanchion are pointing the direction that the lifeline will be going. Secure the stanchion in-place using the supplied bolt and lock nut.
4. Remove the cotter lock ring and bolt from the 5/8-in. (Note: only the 5/8-in. bow shackles may be utilized on the tie-back assemblies because of the higher line tensions seen in the cables.) bow shackle that is attached to the rigging screw of the tieback cable. Attach the bow shackle to the lower hole on the opposite side of the end stanchion from where the lifeline will attach and secure the tie-back cable in place using the bolt and cotter lock ring.
5. Widen the jaws of the 3093 Anchor Clamp to slide over the I-beam flange. Position the clamp at the required location for the tie-back cable, and tighten the clamp to the I-beam after squaring the clamp to the beam. Torque the tightening nut of the clamp to 40-ft. lb.
6. Adjust the rigging screw of the tie-back cable so that it is extended half way out.
7. Attach the second end of the tie-back cable to the d-ring of the Anchor clamp with the supplied 5/8-in. bow shackle and secure the shackle bolt in place with the nut and cotter lock ring. NOTE: If using an adjustable length tie-back cable (6077), the length should be adjusted prior to attaching to the 3093 Anchor Clamp.
8. Tighten the rigging screw until the end stanchion just begins to lean slightly towards the anchor clamp. If the tie-back cable does not become taut after tightening the rigging screw fully, it is permissible to loosen the 3093 Anchor Clamp and slide it along the beam away from the end stanchion to help take up slack in the tie-back cable. Once the clamp has been repositioned, re-tighten the clamp to the I-beam and re-tension the tie-back cable. NOTE: This method of sliding the Anchor Clamp along the I-beam will only work for lifeline systems that are installed parallel to the I-beams; for systems that are installed perpendicular to the I-beams, the length of the adjustable tie-back cable must be changed.
9. Repeat Steps 1 through 8 for the opposite end of the horizontal lifeline.

NOTE: The positioning and installation of the tie-back cables is critical to the proper function of the horizontal lifeline system. For most systems, tie-back cable are positioned so that the angle formed by the surface of the I-beam and the tie-back cable is 45° OR LESS. This means that the Anchor Clamp MUST

User Instructions

6350 Skyline™ Structural Steel HLL System

Reliance Industries, LLC

be secured to the I-beam a distance away from the end stanchion AT LEAST as far the Stanchion is tall (for a 60-in tall End Stanchion, the Anchor Clamp MUST be tightened to the I-beam a MINIMUM of 60-in. away from the Receiver to ensure the tie-back cable angle is no larger than 45°). Some lifeline designs may require the attachment of 4 tie-back cables per system (2 each per end). This is especially true when travel or work performed is not in close proximity to the Lifeline. The maximum lateral strength of the lifeline may be achieved by utilizing dual tie-backs to the structural joints (steel beam ends). Contact Reliance Engineering at (303) 424-8650 with any questions concerning horizontal lifeline installation BEFORE proceeding with the setup or use of any lifeline system.

- Layout the horizontal lifeline cable on a flat surface near where the lifeline will be installed (directly below the I-beam where the stanchions will be installed) and remove all bends. Inspect cable for crush spots, broken wires, weld strikes, or any other deformity that may affect the integrity of the cable. Damaged cables must be removed from service immediately from service. Position the eye end of the wire rope so that it is about 7-ft. (see Figure 5) away from the location of one of the end stanchions.

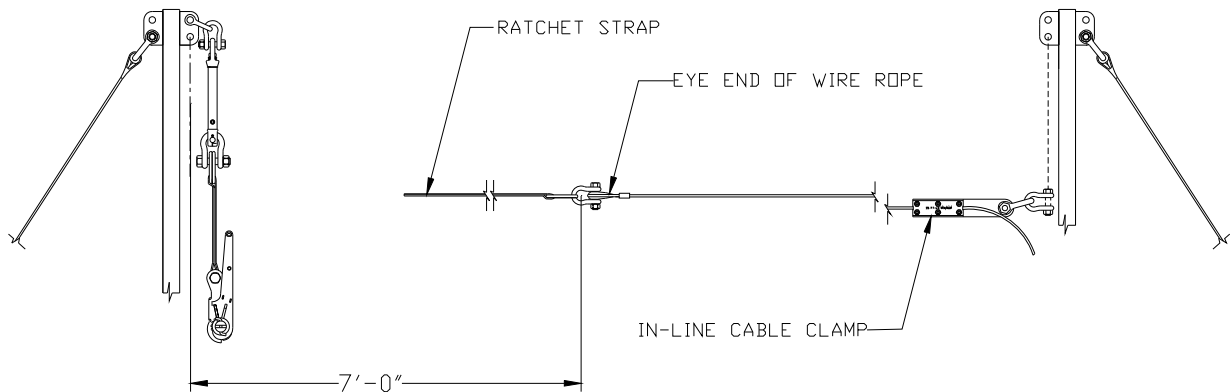

Figure 5

- At the opposite end stanchion, locate the spot on the wire rope where it would contact the anchor lug of the stanchion. A plumb line or laser level may be used to help identify this spot on the cable if the cable has been layed out some distance below where the stanchions were installed, otherwise readjustment of the end-line cable clamp on a trail and error basis may be required. Mark the spot.
- Remove the 6 bolts and lock washers from the top plate of the In-line cable clamp. Set the top plate aside.
- On the mark you have measured off, place the wire rope into the grooved lower plate of the In-line cable clamp. Insure that the end of the cable clamp with the hole in it is placed towards the free end of the wire rope.
- Twist the wire rope and press down into the grooves of the clamp. The wire rope may have to be twisted and untwisted for it to align properly.
- Place the top plate onto the lower plate, and begin tightening the bolts. Tighten the top plate EVENLY to 35 ft-lb. For more detailed information on using the In-Line Cable Clamp, please refer to the “In-Line Cable Clamp Instruction Manual”.

User Instructions

6350 Skyline™ Structural Steel HLL System

Reliance Industries, LLC

16. Attach the bolt of one 1/2-in. bow shackle through the hole of the In-line cable clamp. Tighten the nut and secure in place with the cotter lock ring.
17. Insert a second 1/2-in. bow shackle through the bow of the shackle attached to the In-line cable clamp. Using the shackle bolt, attach the bow shackle to the top hole in the End Stanchion. Replace the nut and cotter lock ring.
18. Attach one 1/2-in. bow shackle through the triangular d-ring of the 10-ft. long ratchet strap, and the eye of the wire rope. Tighten the bow shackle nut and secure with the cotter lock ring.
19. Insert a 1/2-in. bow shackle through the eye of the Skyline shock absorber and the top hole of the second End Stanchion. Secure the bolt with the nut and replace the cotter lock ring.
20. Remove the clevis pin of the Skyline shock absorber and insert the triangular d-ring of the ratchet load binder into the clevis. Replace the clevis pin and cotter lock ring.
21. Begin lifting the horizontal lifeline cable assembly to its intended position (see Figure 6). If bypass stanchions are being used, the cable must be placed through the center of the bypass fittings before the cable is properly tensioned. Pass the free end of the ratchet strap into the slot of the ratchet. Pull the free end of the ratchet strap to help remove slack from the lifeline cable.

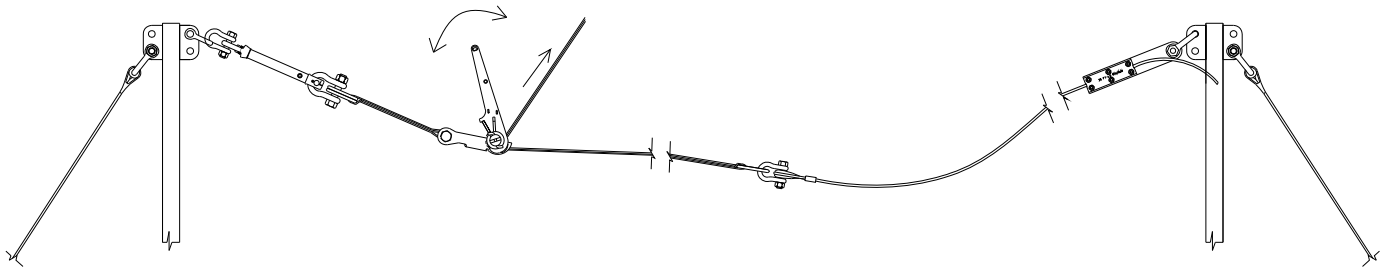

Figure 6

22. While holding the ratchet strap tight, begin tensioning the lifeline, using the ratchet handle.

User Instructions

6350 Skyline™ Structural Steel HLL System

Reliance Industries, LLC

23. Tighten the ratchet load binder until the line tension just releases the load-indicating washer of the shock absorber to spin free. This washer is located just under the eye of the shock absorber (see Figure 7). A freely spinning washer indicates that the cable has been pre-tensioned to 1000 lbf.

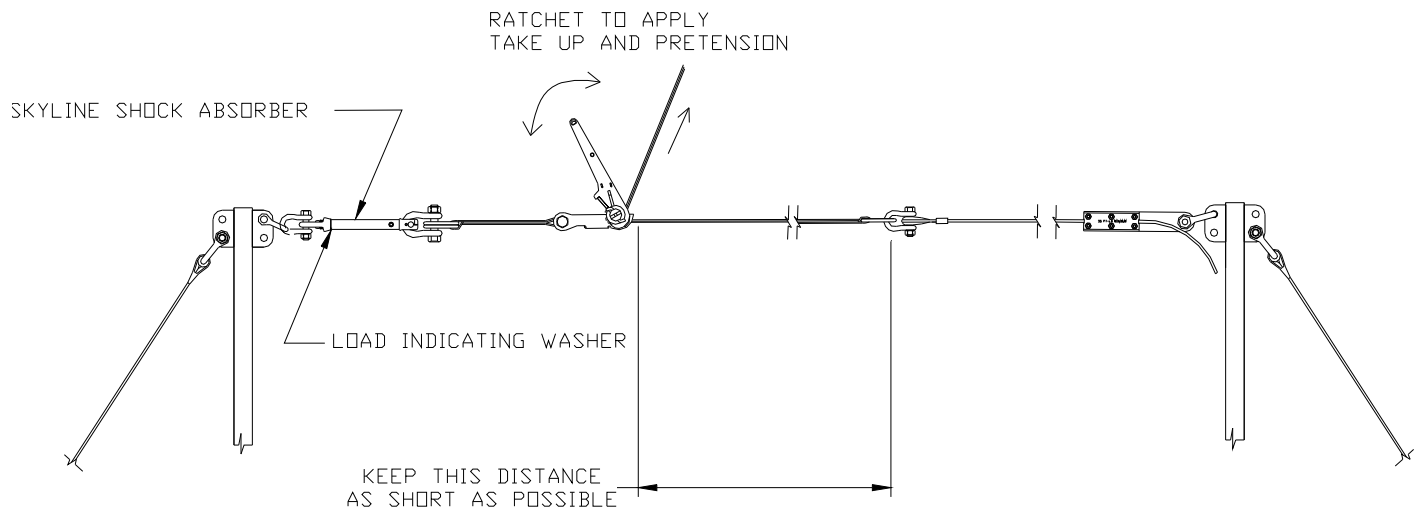

Figure 7

24. Check that the webbing of the ratchet strap has made at least one complete revolution on its mandrel before the correct line tension has been reached. If it has not made a full revolution, release the tension, let 1- to 2-in. of the ratchet strap to slip back out of the load binder and retighten. The strap should now make at least one full revolution before the lifeline is properly tensioned. At least one full revolution is necessary for the tensioner to overcome the maximum load with out slipping.
25. Inspect the installation for any defects, such as missing parts, damage, proper anchorage strengths and configuration, proper pre-tensioning, proper cable alignment, proper elevation, defective or non-compatible components. **DO NOT** authorize system use if any defects or discrepancies are found. Check system installation parameters with system installation parameter documents to assure that the correct installation has been performed.
26. Once the system passes all checks by the competent person, the system may be approved for use, and labeled with a permanent identification tag referencing the following information:
- Identification number that will tie the lifeline to the correct computer generated design documents that identify the original design parameters.
 - Date of installation.
 - Total authorized span length and sub-span length.
 - Total number of people allowed on the system at one time.
 - The minimum required clearance (MRC) below the walking/working surface.
 - The anticipated maximum line tension.
27. A separate tag should also be added indicating date of last inspection by the competent person. Reliance recommends daily inspection, especially on a multi-contractor jobsite and will be happy to assist you in selection of compatible tags.

User Instructions

6350 Skyline™ Structural Steel HLL System

Reliance Industries, LLC

Lifeline Installation Utilizing Strongback Beams

In some installations where it is not possible to use tieback assemblies, or where access is required to be extended to the end of the structure, it is possible to install the lifeline system without the use of tieback cables through the use of the strongback beam. The following sketch shows a typical HLL installation

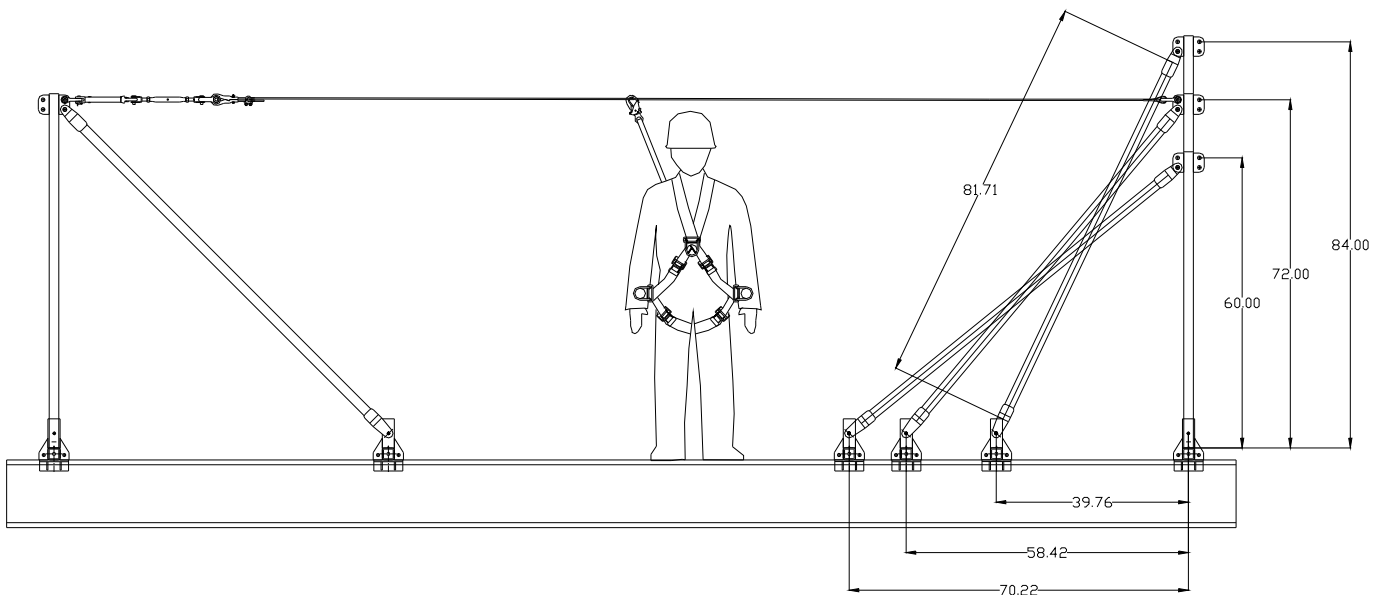

using a strongback beam. Strongbacks transfer the lifeline tension imposed at the top of the stanchion into the structural steel of the walking/working surface. The strongback is supplied in one length and can be used for 5-, 6-, and 7-ft. tall stanchions, and can attach to all existing stanchions and beam clamps without requiring any additional hardware. Care should be taken not to exceed 7,250-lb. of lifeline tension for these installations. This type of system is used typically for lifeline systems where the structural steel runs parallel to the lifeline. This system is not recommended for structures where the structural steel runs perpendicular to the lifeline cable, unless the beam loading requirements are certified by a Professional Engineer (PE). Such applications will require custom length strongbacks; please consult Reliance Engineering for more information.

Installing the 3093 Anchor Clamp

The 3093 Skyline™ Anchor Clamp is designed as a portable anchorage that can be temporarily installed to a structural I-beam to provide a rigid personal fall arrest (PFA) anchorage for fall arrest for one person only or as an anchorage for an HLL system, or as an attachment point for a tie-back cable of an HLL system. Note: the 3093 Anchor Clamp may be used for only one of these purposes at any one time; it



User Instructions

6350 Skyline™ Structural Steel HLL System

Reliance Industries, LLC

may not, for example, be used as a personal fall arrest anchor point while it also has a horizontal lifeline tie-back cable attached to it. It can be attached to the top or bottom flanges of either horizontal or vertical I-beams when properly torqued to 40-ft-lbs.

To attach the Beam Clamp, loosen the hand-knob to desired width, slip over the I-beam flange and tighten the hand-knob as to 40 ft-lb. Check tightness again prior to each use. **DO NOT** stand on either the nut or the threaded rod or the handknob. **DO NOT** use if the clamp does not grip the beam securely enough to prevent any side movement up or down the beam.

Removal is the opposite of installation and should only be performed once it has been verified that there are no individuals attached to the clamp or to a horizontal lifeline attached to the clamp that may be put at risk by the clamps removal.

Training

It is the responsibility of the employer to train all workers prior to using this system (per OSHA 1926.503 (a)(1)). The employer shall provide a training program for each employee who might be exposed to fall hazards. The program shall enable each employee to recognize the hazards of falling and shall train each employee in the procedures to be followed in order to minimize these hazards.

Even when using a full body harness, a quick rescue is critical. To ensure a quick response, a method must be in place to ensure a fallen worker is quickly noticed and his rescue effected.

It is the responsibility of all users of this equipment to understand these instructions, and to be trained in the correct installation, use, and maintenance of this equipment. These individuals must be aware of the consequences of improper installation or use of this equipment. This user manual is not a substitute for a comprehensive training program. Training must be provided on a periodic basis to ensure proficiency of the users.

The employer shall assure that, as necessary, each employee has been trained by a competent person qualified in the following areas:

- a. OSHA regulations governing the use of horizontal lifelines.
- b. Ability to recognize potential fall and workplace hazards.
- c. Method of inspection of safety equipment.
- d. Rescue procedures.
- e. Installation and removal techniques.

Planning for Rescue



User Instructions

6350 Skyline™ Structural Steel HLL System

Reliance Industries, LLC

Prior to system use, a rescue plan must be prepared, the workers must be trained in its use, and the rescue equipment must be on hand to implement it in case of a fall.

Typical rescue plans include (but are not limited to) the following items:

1. List of equipment that must be readily accessible in the event of an emergency and the names of those workers certified to use or operate that equipment.
2. Emergency contact phone numbers (ambulance, hospital, fire department...) and a means to contact them (cell phone, emergency radio).
3. List of employees on the site, and the specific tasks they will perform to effect the rescue.

The equipment that will be used to aid in the rescue of any worker must be attached to structural anchorages independent of those used for the horizontal lifeline system. During installation of horizontal lifeline anchorages, tie-off and equipment attachment hardpoints should be attached, and also clearly marked in such a manner as to provide a means to rescue a worker in any position along the lifeline system.

With the number of potential scenarios and locations for a worker requiring rescue, an on-site rescue team is advantageous. This group of individuals is given the tools, both in equipment and technique, so they can perform a successful and efficient rescue. It is important to provide training on a periodic basis to ensure skills learned are kept current.

Inspection

Prior to each use, the worker must inspect the system for any physical damage, wear, corrosion, or malfunctioning parts. Check the shock absorber for deployment by looking to see if the black slide bearing under the shock absorber eye is exposed. If the washer on the shock absorber freely rotates when not in tension (indicating either misuse or over-tensioning) the shock absorber must be replaced to verify proper pre-tensioning of the horizontal lifeline. Once the shock absorber is deployed, its energy capacity is used up, and it cannot be reset. If the shock absorber deploys, the entire system has seen a fall arrest load and must be removed from service until it is inspected by a competent person who either replaces or repairs and re-certifies the components for use on the system. Once deployed, shock absorbers are not reusable, and must be replaced. With deployment of the shock absorber, it is critical for a competent person to inspect all lifeline components for cracks, distortion of the structural anchorages and connectors. In addition to a normal cable inspection, inspect the swaged eye of the lifeline cable to verify it retains its' original tear-drop shape. Any variation from the original shape indicates excessive load on the cable and it should be replaced. If an inspection reveals a problem or unsafe condition, remove the entire system from service until it can be re-certified by a competent person.

The worker, who must also check the pre-tension prior to each use, must inspect all system components. A formal inspection must be carried out a minimum of once each year, and be formally documented and kept on file with the system parameter documents.



User Instructions

6350 Skyline™ Structural Steel HLL System

Reliance Industries, LLC

Servicing

A qualified person trained in the inspection and servicing of system components must carry out servicing of this system. The company's safety officer should maintain a record log of all servicing and inspection dates. The system and all components must be withdrawn from service if subjected to fall arrest forces. Those components may be returned to service only after being certified by a qualified person. Only original Reliance Industries equipment and replacement parts are approved for use in this system. Contact Reliance Engineering with questions and when in need of assistance.

Warnings and Limitations

Proper care should always be taken to visually scan the work area prior to use. Remove any obstruction, debris, and other materials from, and beneath the work area that could cause injuries or interfere with the operation of this system. Be cautious of swing fall hazards if working horizontally to the side of the lifeline. Always use the shortest lanyard length possible to connect to the lifeline. Be aware of the movements of others on the lifeline at the same time, knowing that if they fall, the sudden motion in the lifeline could pull others off balance. When working at a fixed area, tie off to other suitable overhead anchorages if they exist, allowing the lifeline to be occupied by fewer people.

Users should be familiar with pertinent regulations governing the use of this system and its components. Only trained and competent personnel should install and supervise the use of this system.

Do not exceed manufacturers' recommended span length or maximum number of people on the same lifeline as listed on either the tag attached to the specific horizontal lifeline system, or in the lifeline parameter data sheets.

Do not use these components with any other horizontal lifeline material. Only 3/8 – 7x19 IPS or stainless steel wire rope is allowed, due to its high-energy capacity.

Use only Reliance supplied or qualified compatible components.

If you have any questions regarding the correct installation or use of this product DO NOT USE. Call Reliance Engineering at Ph. (303) 424-8650 or Fax (303) 424-8670.

Inspection Log for HLL Systems

Company: _____ Location: _____ Date: _____
 Job Site: _____ HLL Log No.: _____ System No.: _____

Is this system used as described in the HLL Log No. _____ to conform to design document criteria? _____

Describe non-conforming conditions in the boxes below:

Inspection Criteria	Missing Parts	Labels Readable	Corrosion	Deformed Parts	Cracked Parts/ Broken wires	Excessive Loading
HLL Identity Tag?						
HLL Shock Absorber Label?						
HLL Shock Absorber?						
Rigging Screws?						
End fittings?(combo clamp, etc.)						
Shackles?						
Wire Rope?						
Wire rope eye intact?						
Webbing Strap?						
Ratchet Tensioner?						
Load Rings?						
Anchorage Lugs?						
Bolted Anchor Clamps?						
Stanchions?						
Stanchion Receivers?						
Tie Back cables?						

Is Shock Absorber pre-tension set correctly? _____

Has a Rescue Plan been prepared? _____

Is Rescue Equipment on hand? _____

Have workers been trained in the Rescue Procedures and been given a copy of the Rescue Plan? _____

Skyline™ Horizontal Lifeline Diagram

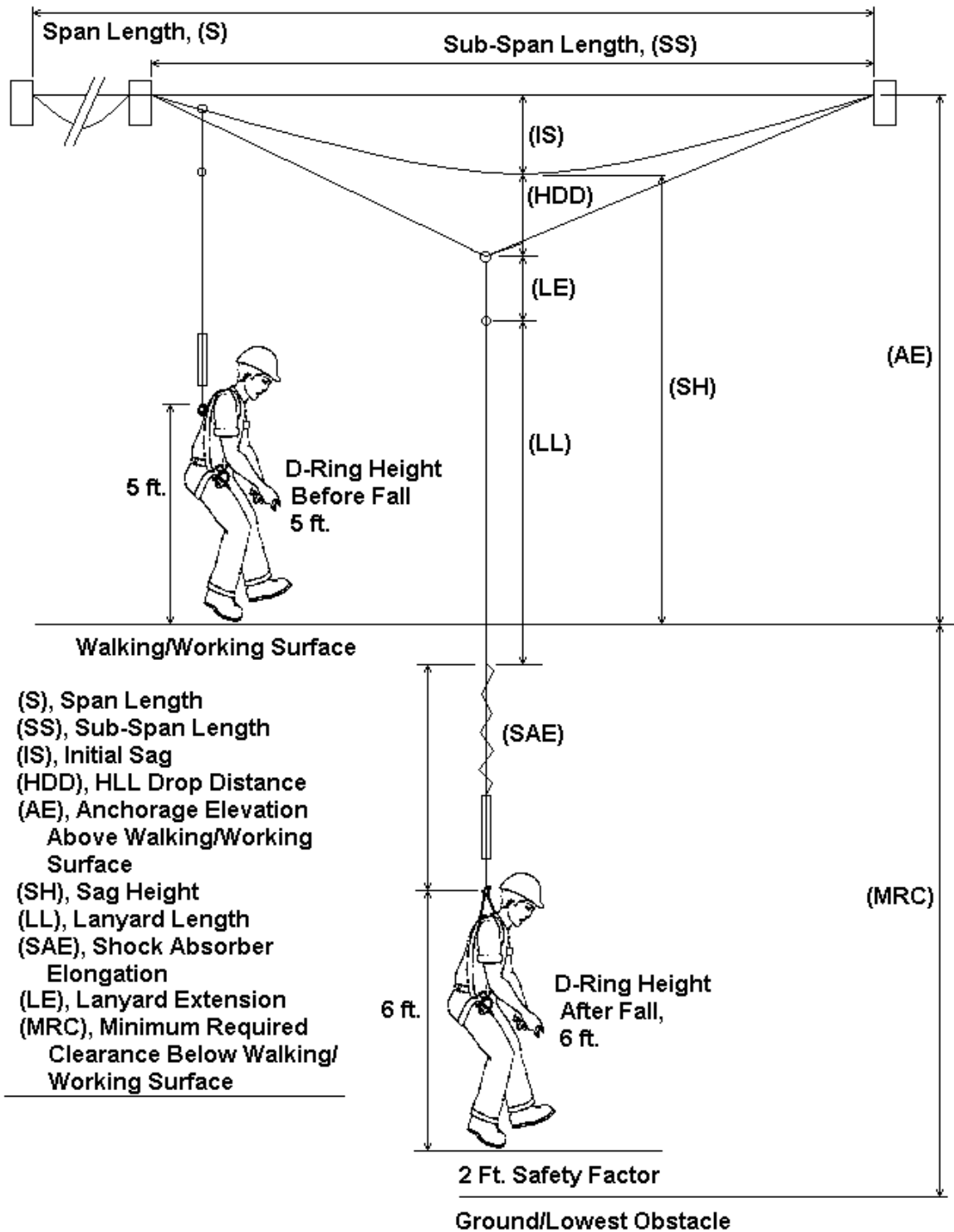

- (S), Span Length
- (SS), Sub-Span Length
- (IS), Initial Sag
- (HDD), HLL Drop Distance
- (AE), Anchorage Elevation Above Walking/Working Surface
- (SH), Sag Height
- (LL), Lanyard Length
- (SAE), Shock Absorber Elongation
- (LE), Lanyard Extension
- (MRC), Minimum Required Clearance Below Walking/Working Surface